

SUPERtrol II

Multi-Function Flow Computer

- “EZ Setup”- Guided Setup for First Time Users
- Liquid, Gas, Steam and Heat Flow Equations
- Utility Metering
- Menu Selectable Hardware & Software Features
- Internal Data Logging Option
- Isolated Pulse and Analog Outputs Standard
- RS-232 Port Standard, Modbus RTU RS-485 Optional
- Windows™ Setup Software
- NX19 Gas Equations, Stacked DP Transmitters
- DDE Server & HMI Software Available
- Remote Metering by Wireless or Modem and TROLlink Remote Metering Software Available



Description:

The SUPERtrol II Flow Computer satisfies the instrument requirements for a variety of flowmeter types in liquid, gas, steam and heat applications. Multiple flow equations are available in a single instrument with many advanced features.

The alphanumeric display offers measured parameters in easy to understand format. Manual access to measurements and display scrolling is supported

The versatility of the Flow Computer permits a wide measure of versatility within the instrument package. The various hardware inputs and outputs can be “soft” assigned to meet a variety of common application needs. The user “soft selects” the usage of each input/output while configuring the instrument. Consider the following illustrative examples.

The isolated analog output can be chosen to follow the volume flow, corrected volume flow, mass flow, temperature, pressure, or density by means of a menu selection. Most hardware features are assignable by this method.

The user can assign the standard RS-232 Serial Port for external data logging, transaction printing, or for connection to a modem for remote meter reading.

A Service or Test mode is provided to assist the user during start-up system check out by monitoring inputs and exercising outputs. The system setup can also be printed.

Specifications:

Environmental

Operating Temperature: 0 to +50 C
Storage Temperature: -40 to +85 C
Humidity : 0-95% Non-condensing
Materials: UL, CSA, VDE approved

Display

Type: 2 lines of 20 characters
Types: Backlit LCD and VFD ordering options
Character Size: 0.3" nominal
User selectable label descriptors and units of measure

Keypad

Keypad Type: Membrane Keypad
Keypad Rating: Sealed to Nema 4
Number of keys: 16

Enclosure

Enclosure Options: Panel, Wall, Explosion Proof
Size: See Dimensions
Depth behind panel: 6.5" including mating connector
Type: DIN
Materials: Plastic, UL94V-0, Flame retardant
Bezel: Textured per matt finish

Power Input

The factory equipped power option is internally fused. An internal line to line filter capacitor is provided for added transient suppression. MOV protection for surge transient is also supported

Universal AC Power: 85 to 276 Vrms, 50/60 Hz

DC Power Option: 24 VDC (16 to 48 VDC)

Power Consumption

AC Power: 6.5 V/A (6.5W)

DC Power: 300 mA max.

Flow Meter Types:

Linear: Vortex, Turbine, Positive Displacement, Magnetic, GilFlo, GilFlo 16 point, ILVA 16 Point and others

Square Law: Orifice, Venturi, Nozzle, V-Cone, Wedge, Averaging Pitot, Target and others

Multi-Point Linearization: May be used with all flowmeter types. Including: 16 point, UVC and dynamic compensation.

Flow Inputs:

Analog Input:

Accuracy: 0.02% FS at 20° C

Ranges

Voltage: 0-10 VDC, 0-5 VDC, 1-5 VDC

Current: 4-20 mA, 0-20 mA,

4-20 mA stacked, 0-20 mA stacked

Basic Measurement Resolution: 16 bit

Update Rate: 4 updates/sec

Automatic Fault detection: Signal over/under-range, Current Loop Broken

Calibration: Operator assisted learn mode

Extended calibration: Learns Zero and Full Scale of each range

Fault Protection:

Fast Transient: 500 V Protection (capacitive clamp)

Reverse Polarity: No ill effects

Over-Voltage Limit: 50 VDC Over voltage protection

Over-Current Protection: Internally current limited protected to 24VDC

Pulse Inputs:

Number of Flow Inputs: one
 Input Impedance: 10 k Ω nominal
 Trigger Level: (menu selectable)
 High Level Input
 Logic On: 2.5 to 30 VDC
 Logic Off: 0 to 2 VDC
 Low Level Input (mag pickup)
 Selectable sensitivity: 10 mV and 100 mV
 Minimum Count Speed: 0.25 Hz (to maintain rate display)
 Maximum Count Speed: Selectable: 0 to 50 kHz
 Overvoltage Protection: 50 VDC
 Update Speed: 1 update/sec.

Temperature, Pressure, Density Inputs

The compensation inputs usage are menu selectable for temperature, temperature 2, pressure, density or not used.

Calibration: Operator assisted learn mode

Operation: Ratiometric

Basic Measurement Resolution: 16 bit

Update Rate: 2 updates/sec minimum

Automatic Fault detection:

Signal Over-range/under-range
 Current Loop Broken
 RTD short
 RTD open
 Reverse Polarity: No ill effects
 Over-Current Limit
 (current input) Internally limited to protect input to 24 VDC

Available Input Ranges

Current: 4-20 mA, 0-20 mA
 Resistance: 100 Ohms DIN RTD
 Accuracy: 0.02% FS at 20° C

100 Ohm DIN RTD (DIN 43-760, BS 1904):

Three Wire Lead Compensation
 Internal RTD linearization learns ice point resistance
 1 mA Excitation current with reverse polarity protection
 Temperature Resolution: 0.1°C
 Temperature Accuracy: 0.5°

Stored Information (ROM)

Steam Tables (saturated & superheated),
 Fluid Properties: Water, Air, Natural Gas, A Variety of User
 Entered Industrial Fluids or Generic

User Entered Stored Information (EEPROM / Nonvolatile RAM)

Transmitter Ranges, Signal Types
 Fluid Properties
 (reference density, expansion factor, specific heat,
 viscosity, isentropic exponent, combustion heating
 value, Z factor)
 Units Selections (English/Metric)
 Language Translations (optional)

Excitation Voltage

24 VDC @ 100 mA (fault protected with self resetting fuse)

Relay Outputs

The relay outputs usage is menu assignable to (Individually for each relay) Hi/Lo Rate Alarm, Hi/Lo Temperature Alarm, Hi/Lo Pressure Alarm, Pulse Output (pulse options), Wet Steam or General purpose warning (security).
 Number of relays: 2 (3 optional)
 Contact Style: Form C contacts (Form A with 3 relay option)
 Contact Ratings: 240 V, 5 amp

Analog Outputs

The analog outputs are menu assignable to correspond to the Uncompensated Volume Rate, Corrected Volume Rate, Mass Rate, Heat Rate, Temperature, Density, Pressure or Delta Temperature.

Number of Outputs: 2

Type: Isolated Current Sourcing (shared common)

Available Ranges: 0-20 mA, 4-20 mA (menu selectable)

Resolution: 16 bit

Accuracy: 0.05% FS at 20 Degrees C

Update Rate: 5 updates/sec

Temperature Drift: Less than 200 ppm/C

Maximum Load: 1000 ohms

Compliance Effect: Less than .05% Span

60 Hz rejection: 40 dB minimum

EMI: No effect at 3 V/M

Calibration: Operator assisted Learn Mode

Averaging: User entry of DSP Averaging constant to cause a smooth control action

Listing: CE Compliant, UL/C-UL Pending

Serial Communication

The serial port can be used for printing, datalogging, modem connection, two way paging and communication with a computer.

RS-232:

Device ID: 01-99
 Baud Rates: 300, 600, 1200, 2400, 4800, 9600, 19200
 Parity: None, Odd, Even
 Handshaking: None, Software, Hardware
 Print Setup: Configurable print list and formatting

RS-485: (optional 2nd COM port)

Device ID: 01-247
 Baud Rates: 300, 600, 1200, 2400, 4800, 9600, 19200
 Parity: None, Odd, Even
 Protocol: Modbus RTU (Half Duplex)

Data Logging

The data logger captures print list information to internal storage for approximately 5000 transactions. This information can be used for later uploading or printing. Storage format is selectable for Comma-Carriage Return or Printer formats.

Isolated Pulse output

The isolated pulse output is menu assignable to Uncompensated Volume Total, Compensated Volume Total, Heat Total or Mass Total.

Pulse Output Form (menu selectable): Open Collector NPN or 24 VDC voltage pulse

Nominal On Voltage: 24 VDC

Maximum Sink Current: 25 mA

Maximum Source Current: 25 mA

Maximum Off Voltage: 30 VDC

Saturation Voltage: 0.4 VDC

Pulse Duration: User selectable

Pulse output buffer: 8 bit

Fault Protection

Reverse polarity:

Shunt Diodes

Over-current Protected

Over-voltage Protected

Real Time Clock

The Flow Computer is equipped with a pseudo nonvolatile real time clock with display of time and date.

Format:

24 hour format for time

Day, Month, Year for date

Fig. 1: Standard Dimensions

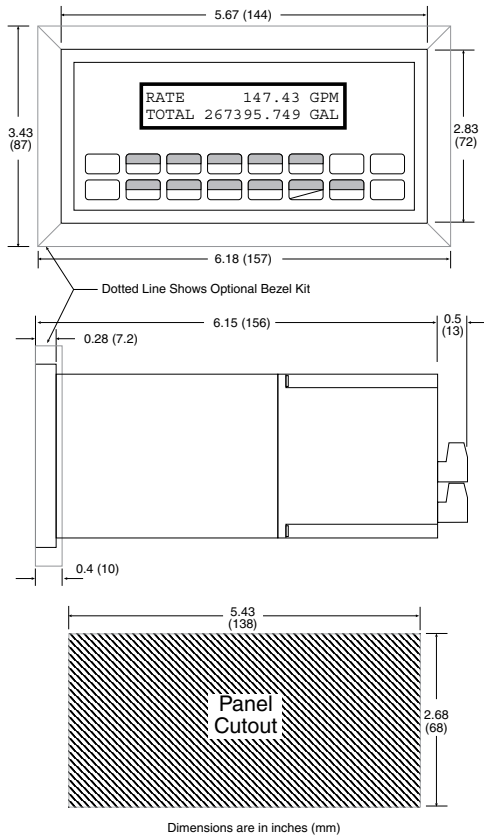
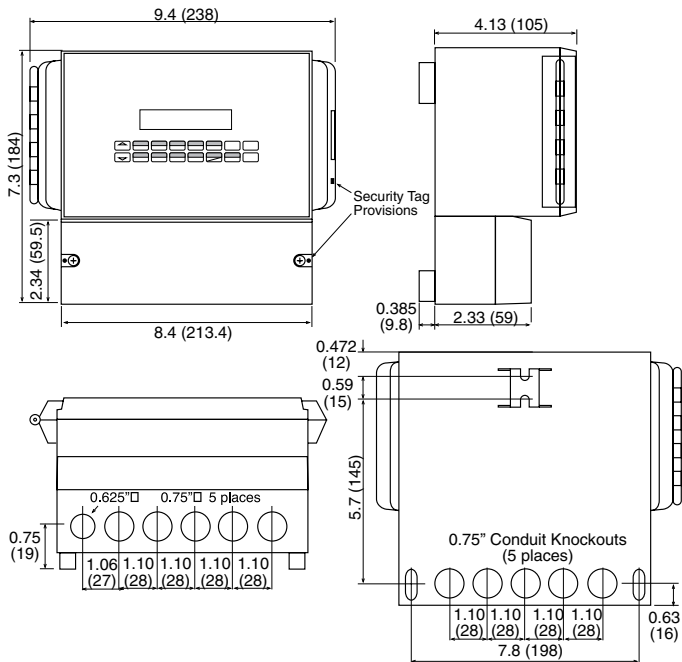

Fig. 2: Wall Mount ("W" mounting option) Dimensions



Terminal Designations

1	DC OUTPUT	2	FLOW	3	IN	4	COMMON	5	TEMPERATURE	6	IN	7	RTD EXCIT (+)	8	RTD SENS (+)	9	RTD SENS (-)	10	DC OUTPUT	11	RTD EXCIT (+)	12	RTD SENS (+)	13	RTD SENS (-)	14	PRESSURE (TEMP 2)	15	IN	16	PULSE OUTPUT (+)	17	PULSE OUTPUT (-)	18	ANALOG OUTPUT 1 (+)	19	ANALOG OUTPUT 2 (+)	20	ANALOG OUTPUT COMMON (-)	21	NO	22	COM RLY1	23	NC	24	COM RLY2	25	NO	26	AC LINE	27	DC (+)	28	DC (-)	29	POWER IN
---	-----------	---	------	---	----	---	--------	---	-------------	---	----	---	---------------	---	--------------	---	--------------	----	-----------	----	---------------	----	--------------	----	--------------	----	-------------------	----	----	----	------------------	----	------------------	----	---------------------	----	---------------------	----	--------------------------	----	----	----	----------	----	----	----	----------	----	----	----	---------	----	--------	----	--------	----	----------

Terminal Layout

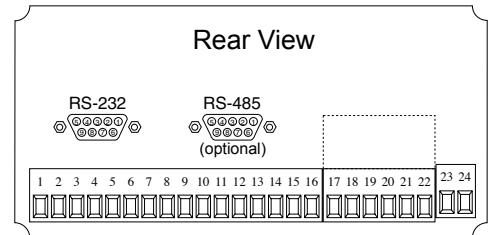

Ordering Information

Example ST2 L 1 0 P M

Series: ST2 = Flow Computer

Display Type: L = LCD, V = VFD

Input Power: 1 = 85 to 276 VAC, 3 = 24 VDC (16 to 48 VDC)

Network Card: 0 = None, 1 = RS485/Modbus (optional 2nd COM port)

Mounting: P = Panel Mount (see Fig. 1), N = NEMA 4 Wall Mount (see NEMAtrolST4X), W = NEMA 12/13 Wall Mount w/ Clear Cover (see Fig. 2), E = Explosion Proof (No Button Access) (see XHVD 7/4), X = Explosion Proof (with Button Access) (see XTROL 7/4)

Options: 1 = Peak Demand, 2 = AGA NX-19 calculation for natural gas, 3 = Three Relays, 4 = Stacked DP option, 5 = Datalogger option (consult factory), 6 = Stack Emissions Controller option, 7 = Manifold Flowmeter Controller option, 9 = 3 Relay Super Chip (options 1, 2, 4, 6, 7), 10 = 2 Relay Super Chip (options 1, 2, 4, 6, 7), 13 = Superchip; 2 relay, Positive heat only, 14 = Superchip; 3 relay, Positive heat only, ET = Extended Temperature; -4°F to 131°F (-20°C to 55°C), IM = Internal Modem, M = Modem Power Option, TB = RS485 Terminal Block for Panel Mount Enclosure, TU = Translation Utility Disk

Accessories: KEPS-KEP1-32 = KEP RS232 DDE server for SUPERtrol, KEPS-MBS32 = Modbus RTU OPC/DDE server, Modem Available, see MPP-2400 and MPP-2400N (requires M option), Two Way Pager Available, see MPP-TWP (requires M option), Serial printer available, see P1000, P295, Ethernet Port Server available, see IEPS, RS-422/485 to RS-232 Communication Adaptor available, see CA285, Remote metering and data collection software available, see TROLlink