

eMT3105P

Human Machine Interface with 10.4" SVGA TFT Display



Features

- 10.4" 800x600 TFT LCD
- Fan-less Cooling System
- Built-in 256MB Flash Memory and RTC
- NEMA4/IP65 Compliant Front Panel
- Supports SD/SDHC Cards
- Power Isolator Inside
- Com1 or Com3 RS485 2W Supports MPI 187.5K
- CAN bus Device Supports CANopen Protocol
- Com1 / Com3 RS485 & CAN bus Built-in Isolation

Display	Display	10.4" TFT
	Resolution	800 x 600
	Brightness (cd/m ²)	400
	Contrast Ratio	400:1
	Backlight Type	LED
	Backlight Life Time	30,000 hr.
	Colors	262K
Touch Panel	Type	4-wire Resistive Type
	Accuracy	Active Area Length(X)±2%, Width(Y)±2%
Memory	Storage(MB)	256
	RAM (MB)	256
Processor		32Bit RISC CPU 800MHz
I/O Port	SD Card Slot	SD/SDHC
	USB Host	USB 2.0 x 1
	USB Client	USB 2.0 x 1
	Ethernet	10/100 Base-T
	COM Port	COM1 (RS-232/RS-485 2W/4W), COM3(RS-232/RS-485 2W), CAN bus
	Audio	Audio Line Out – 3.5 mm jack x 1
RTC		Yes
Power	Input Power	24±20%VDC
	Power Consumption	800m A@24V
	Power Isolation	Built In
	Voltage Resistance	500VAC (1 min)
	Isolation Resistance	Exceed 50MΩ at 500VDC
	Vibration Endurance	10 to 25Hz(X,Y,Z direction 2G 30 minutes)
Specification	Enclosure	Plastic
	Dimensions WxHxD	286 x 212 x 50mm
	Panel Cutout (mm)	259 x 201
	Weight (kg)	Approx. 1.6 kg
Operation	Protection Structure	IP65 front panel (O ring seal)
	Storage Temperature	-20°~60°C (-4° ~ 140°F)
	Operating Temperature	0°~ 50°C (32° ~ 122°F)
	Operating Humidity	10% ~ 90% RH (non-condensing)
CE/FCC		EN 55022: 2006+A1: 2007, Class A EN 61000-3-2: 2006 EN61000-3-3: 2008 EN 55024: 1998+A1: 2001+A2: 2003
Software		EasyBuilder Pro

Dimensions of eMT3105P

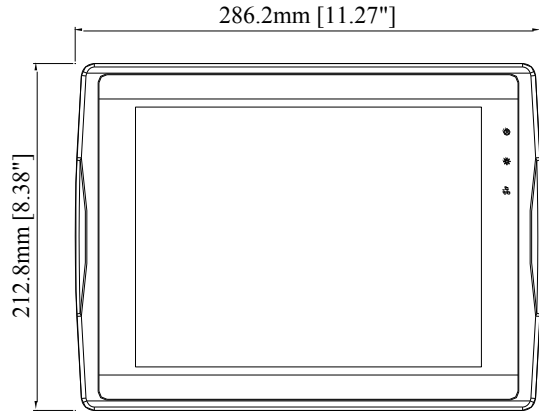

Front View

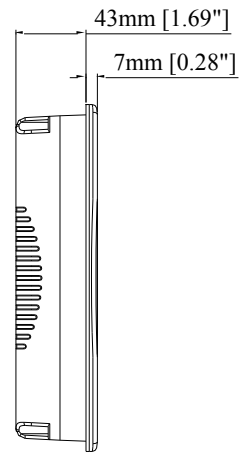

Side View

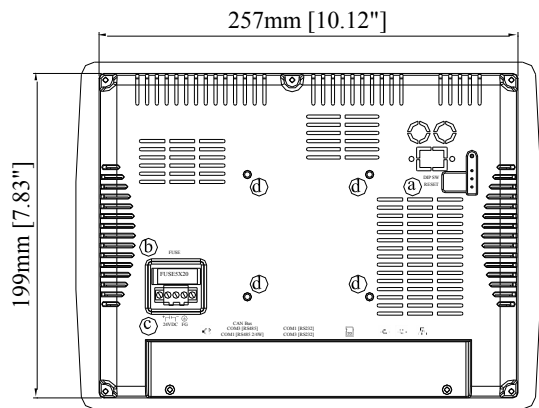

Rear View

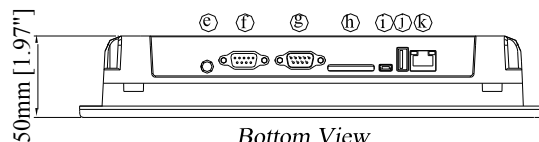
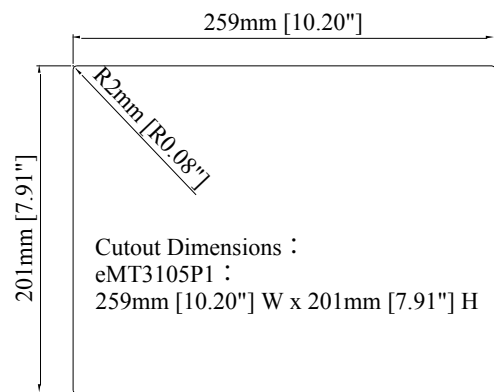

Bottom View

a	DIP SW & Reset Button
b	Fuse
c	Power Connector
d	VESA 75mm Screw Holes
e	Line Out
f	Com1 RS485, Com3 RS485, CAN bus
g	Com1 RS232, Com3 RS232
h	SD CARD SLOT
i	USB Client port
j	USB Host port
k	Ethernet Port

Ordering Information

□ eMT3105P

10.4" TFT LCD HMI,
256MB flash memory/256MB RAM on board

□ FLZ485000

Multi-Connector cable Com1[485]/Com3[485]/CAN Bus

□ FLZ232000

Multi-Connector cable Com1[232]/Com3[232]

